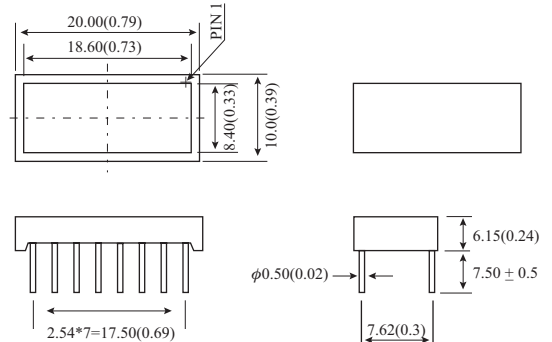

**DESCRIPTION:**

The KWL-1020Ux series is 10.16mm x 20.16mm rectangular type light bar display designed for a variety of applications where a large source of light is required, such as panel indicators, backlight legends and light arrays.

**PACKAGE DIMENSIONS**

**ABSOLUTE MAXIMUM RATINGS: (Ta=25°C)**

Parameter	Max
Reverse Voltage per segment	5 V
Reverse Current per segment (Vr = 5V)	100μA
Derating Linear from 25°C per segment	0.4mA/°C
Operating Temperature Range	-40°C To 85°C
Storage Temperature Range	-40°C To 100°C
Soldering Temperature 1.6mm(1/16") from body for 5 sec. at 260°C	

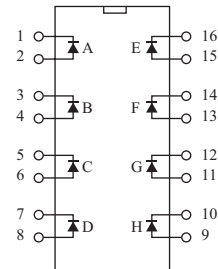
- NOTES : 1. All dimensions are in millimeters (inches).  
 2. Tolerance is ±0.25mm(0.010) unless otherwise specified.  
 3. Specifications are subject to change without notice.  
 4. NP: No Pin.  
 5. NC: No Connect.

**INTERNAL CIRCUIT DIAGRAM**

**TESTING CONDITION FOR EACH PARAMETER :**

Parameter	Symbol	Unit	Test Condition
Forward Voltage	Vf	V	If=20mA
Peak Emission Wave Length	λp	nm	If=20mA
Spectral Line Half-Width	Δλ	nm	If=20mA
Reverse Current	Ir	μA	Vr=5V
Average Luminous Intensity	Iv	μ cd	If=10mA

**PART NO. SELECTION AND APPLICATION INFORMATION (RATINGS AT 25°C AMBIENT)**

Part No.	Chip		C.C or C.A	Wave Length λp (nm)	Absolute Maximum Ratings				Electro-optical Characteristic					
	Raw Material	Emitted Color			Δλ (nm)	Pd (mW)	If (mA)	If (Peak) (mA)	Vf (V) Per Chip			If (Rec) (mA)	Iv (mcd)	
									Min.	Typ.	Max.		Min.	Typ.
KWL-1020U3	GaAsP/GaP	Hi-Eff. Red	Common	635	45	100	50	100	1.7	1.9	2.6	10-20	6.0	16.0
KWL-1020US	GaAlAs	Super Red		660	20	100	50	100	1.5	1.9	2.6	10-20	15.0	32.0
KWL-1020U2	GaP	Green		565	30	100	50	100	1.7	2.2	2.6	10-20	6.0	14.0
KWL-1020UG	GaP	Super Green		570	30	100	50	100	1.7	2.2	2.6	10-20	8.5	20.0
KWL-1020U6	GaAsP/GaP	Yellow		585	30	100	50	100	1.7	1.9	2.6	10-20	6.0	14.0

- REMARKS : 1. The average luminous intensity is obtained by summing the luminous intensity of each segment and dividing by the total number of segments.  
 2. Luminous intensity is measured with a light sensor and filter combination that approximates the CIE (International Commission on Illumination) eye-response curve.  
 3. Clean only by pure water, isopropanol, ethanol, Freon TF (or equivalent).