

DESCRIPTION:

The 224 Super Bright series is conventional 3mm LED Lamps utilizing higher intensity materials to achieve superior performance.

The semi-conductor materials used are:

GaAlAs for (224HR3C/HR3D)

GaP for (224VGC/VGD, 224YGUC/YGUD)

GaAsP/GaP for (224VYC/VYD)

AlGaInP for (224RS1C/RS1D, 224UY1C/UY1D)

ABSOLUTE MAXIMUM RATINGS: (Ta=25°C)

Reverse Voltage	5 Volt
Reverse Current (Vr =5V)	100µA
Operating Temperature Range	-40°C To 85°C
Storage Temperature Range	-40°C To 100°C
Lead Soldering Temperature (1.6mm (1/16)From Body)	260°C For 5 Seconds

NOTES : 1. All dimensions are in millimeters.

2. Lead spacing is measured where the leads emerge from the package.

3. Protuded resin under flange is 1.5 mm (0.059") Max.

4. Specifications are subject to change without notice.

PACKAGE DIMENSIONS

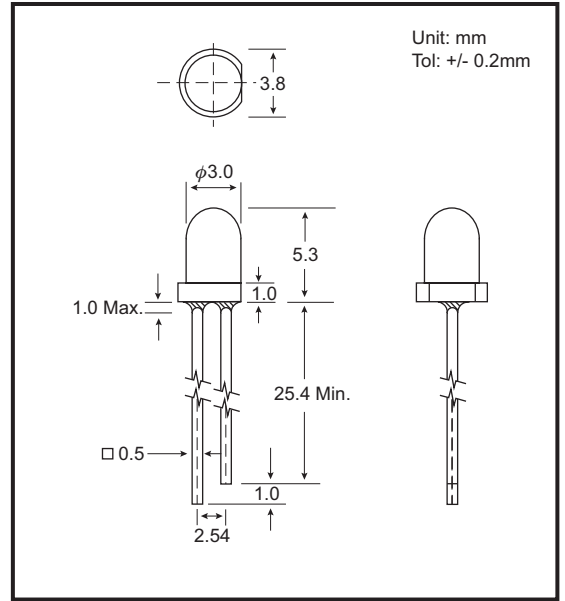

PART NO. SELECTION AND APPLICATION INFORMATION (RATINGS AT 25°C AMBIENT)

Part No.	Emitted Color	Lens Color	Peak Wavelength λp (nm)	Vf (v)		Rec. If (mA).	Iv (mcd)		View Angle 2θ1/2(Deg)
				Min	Max		Min	Typ.	
GB-224HR3D	Super Red	Red Diffused	660	1.7	2.6	10-20	25.0	300.0	35
GB-224RS1D	Super Red	Red Diffused	635	1.7	2.6	10-20	35.0	50.0	35
GB-224VGD	Super Green	Green Diffused	565	1.7	2.6	10-20	35.0	50.0	35
GB-224YGUD	Super Green	Green Diffused	565	1.7	2.6	10-20	50.0	70.0	35
GB-224VYD	Super Yellow	Yellow Diffused	585	1.7	2.6	10-20	20.0	30.0	35
GB-224UY1D	Super Yellow	Yellow Diffused	590	1.7	2.6	10-20	150.0	200.0	35
GB-224HR3C	Super Red	Water Clear	660	1.7	2.6	10-20	105.0	150.0	18
GB-224RS1C	Super Red	Water Clear	635	1.7	2.6	10-20	105.0	150.0	18
GB-224VGC	Super Green	Water Clear	565	1.7	2.6	10-20	90.0	130.0	18
GB-224YGUC	Super Green	Water Clear	565	1.7	2.6	10-20	120.0	170.0	18
GB-224VYC	Super Yellow	Water Clear	585	1.7	2.6	10-20	70.0	100.0	18
GB-224UY1C	Super Yellow	Water Clear	590	1.7	2.6	10-20	340.0	480.0	18

TESTING CONDITION FOR EACH PARAMETER :

PARAMETER:	SYMBOL	UNIT	TEST CONDITION
REVERSE VOLTAGE	Vr	VOLT	Vr = 5.0 Volt
REVERSE CURRENT	Ir	µA	If = 20mA
FORWARD VOLTAGE	Vf	VOLT	If = 20mA
LUMINOUS INTENSITY	Iv	MCD	If = 20mA
VIEWING ANGLE	2θ1/2	DEGREE	
RECOMMENDED OPERATING CURRENT	If (Rec)	mA	

