

DESCRIPTION:

The 762 series is a 1.4 x 4 x 6.2mm rectangular package with short lead which is most suitable for panel indicating application.
 GaP for (762HD, 762GD)
 GaAsP/GaP for (762RHD, 762YD, 762SD)

ABSOLUTE MAXIMUM RATINGS: (Ta=25°C)

Reverse Voltage	5 Volt
Reverse Current (Vr =5V)	100µA
Operating Temperature Range	-40°C To 85°C
Storage Temperature Range	-40°C To 100°C
Lead Soldering Temperature (1.6mm (1/16)From Body)	260°C For 5 Seconds

- NOTES : 1. All dimensions are in millimeters.
 2. Lead spacing is measured where the leads emerge from the package.
 3. Protuded resin under flange is 1.5 mm (0.059") Max.
 4. Specifications are subject to change without notice.

PACKAGE DIMENSIONS

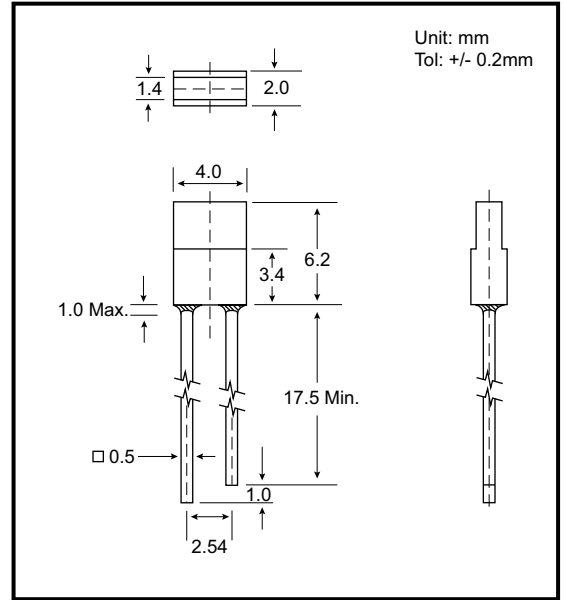

PART NO. SELECTION AND APPLICATION INFORMATION (RATINGS AT 25°C AMBIENT)

Part No.	Emitted Color	Lens Color	Peak Wavelength λp (nm)	Vf (v)		Rec. If (mA)	Iv (mcd)		View Angle 2θ1/2(Deg)
				Min	Max		Min	Typ.	
GB-762HD	Bright Red	Red Diffused	697	1.7	2.6	5-10	0.3	0.6	120
GB-762RHD	Bright Red	Red Diffused	660	1.7	2.6	10-20	0.4	1.2	120
GB-762GD	Green	Green Diffused	565	1.7	2.6	10-20	0.4	1.2	120
GB-762YD	Yellow	Yellow Diffused	585	1.7	2.6	10-20	0.4	1.2	120
GB-762SD	Orange	Orange Diffused	610	1.7	2.6	10-20	0.4	1.2	120

TESTING CONDITION FOR EACH PARAMETER :

PARAMETER:	SYMBOL	UNIT	TEST CONDITION
REVERSE VOLTAGE	Vr	VOLT	Vr = 5.0 Volt
REVERSE CURRENT	Ir	µA	If = 20mA
FORWARD VOLTAGE	Vf	VOLT	If = 20mA
LUMINOUS INTENSITY	Iv	MCD	If = 20mA
VIEWING ANGLE	2θ1/2	DEGREE	
RECOMMENDED OPERATING CURRENT	If (Rec)	mA	

